



Model

2000633

SBP-1200D Disconnect

FEATURES

- | | |
|--|---|
| <ul style="list-style-type: none"> • Prototype & Production Tested Design • Wide range of options and accessories available • Simple access for maintenance and operations • Weatherproof enclosure with NEMA 3R compliance • Safety guards for all electrical connections • Lockable latches standard • All steel powdercoated enclosure construction and design • 400 Amp Hubbell Cam Lock Connections | <p>Disconnect:</p> <ul style="list-style-type: none"> • UL and CSA standards • Roll cage with integrated fork pockets and wheel kit • Heavy duty mobile rated design • Aluminum gland system • Bilingual decal package ready for all markets • Powder coated |
|--|---|

UNIT SPECIFICATIONS

Rated Voltage	600 Vac/Vdc
Rated Current	1200 Amp
Cam Lock Type	Hubbell 400 Amp
Number of Phases	3
Rated Interrupt Current	100 kA @ 240 VAC 65 kA @ 480 VAC 42 kA @ 600 VAC
Connection Type	5 Wire (L1, L2, L3, N, GND) 4 Per Phase and Neutral 2 Ground
Length [INCHES]	25.5 in
Width [INCHES]	44.5 in
Height [INCHES]	45.75 in
Weight [LBS]	475 lbs
Compliance / Approvals	SPE-1000, CSAC22.2, UL1640 Compliant Design, UL 489, CE Compliant

DIMENSIONS

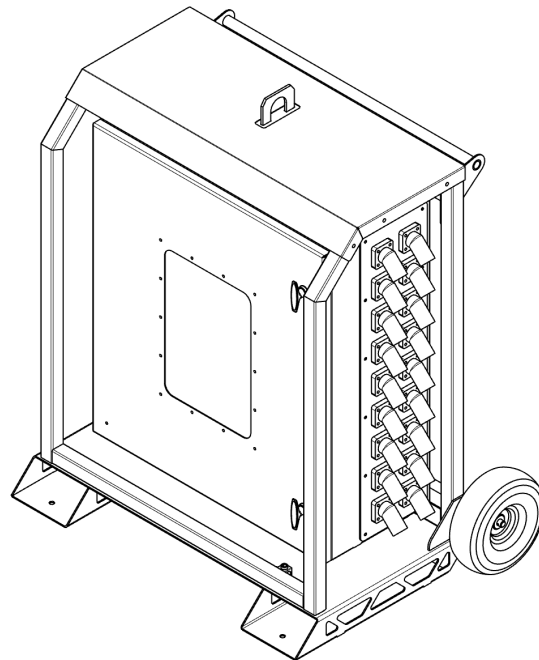
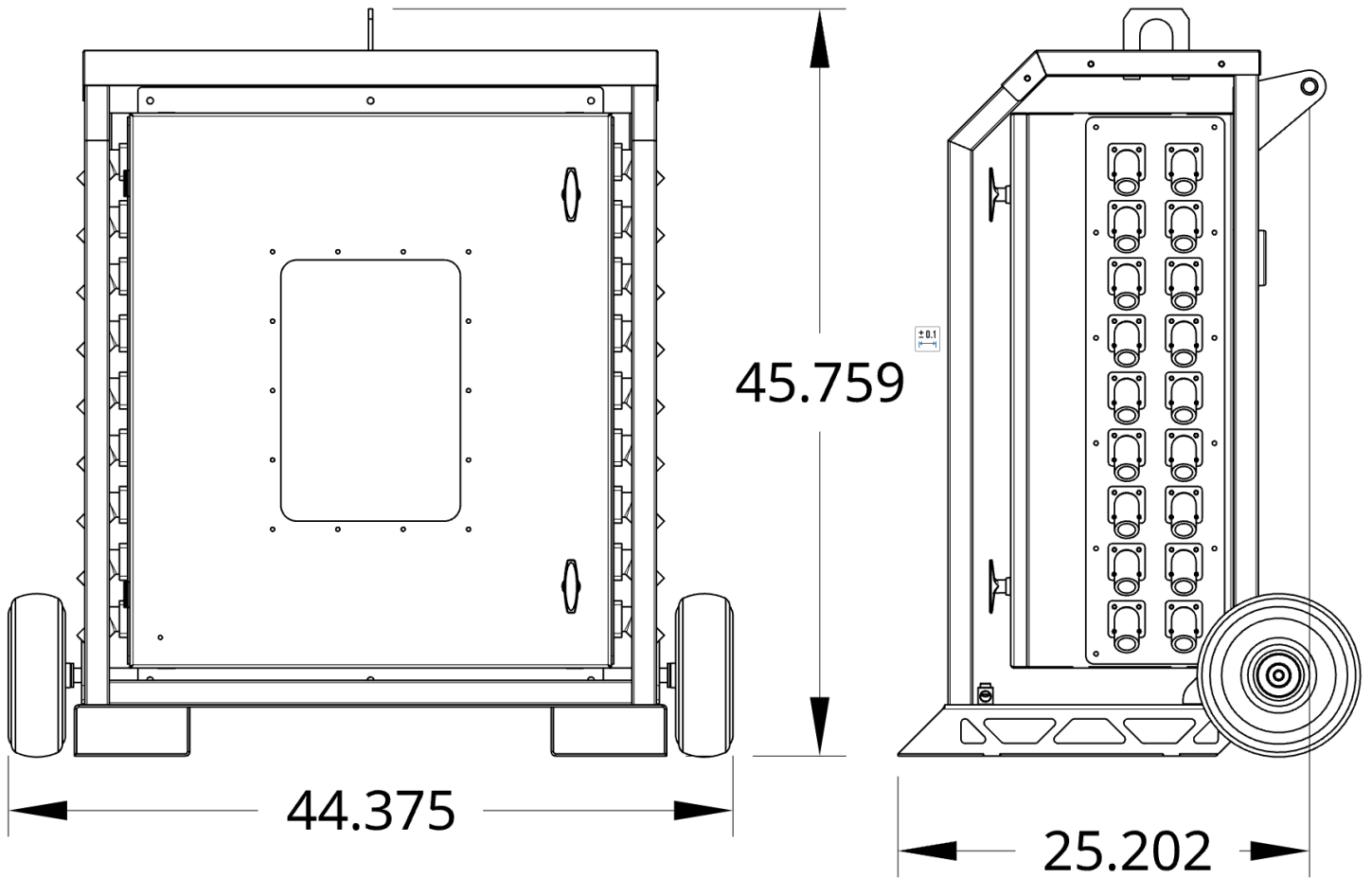

BASE WIRING DIAGRAM

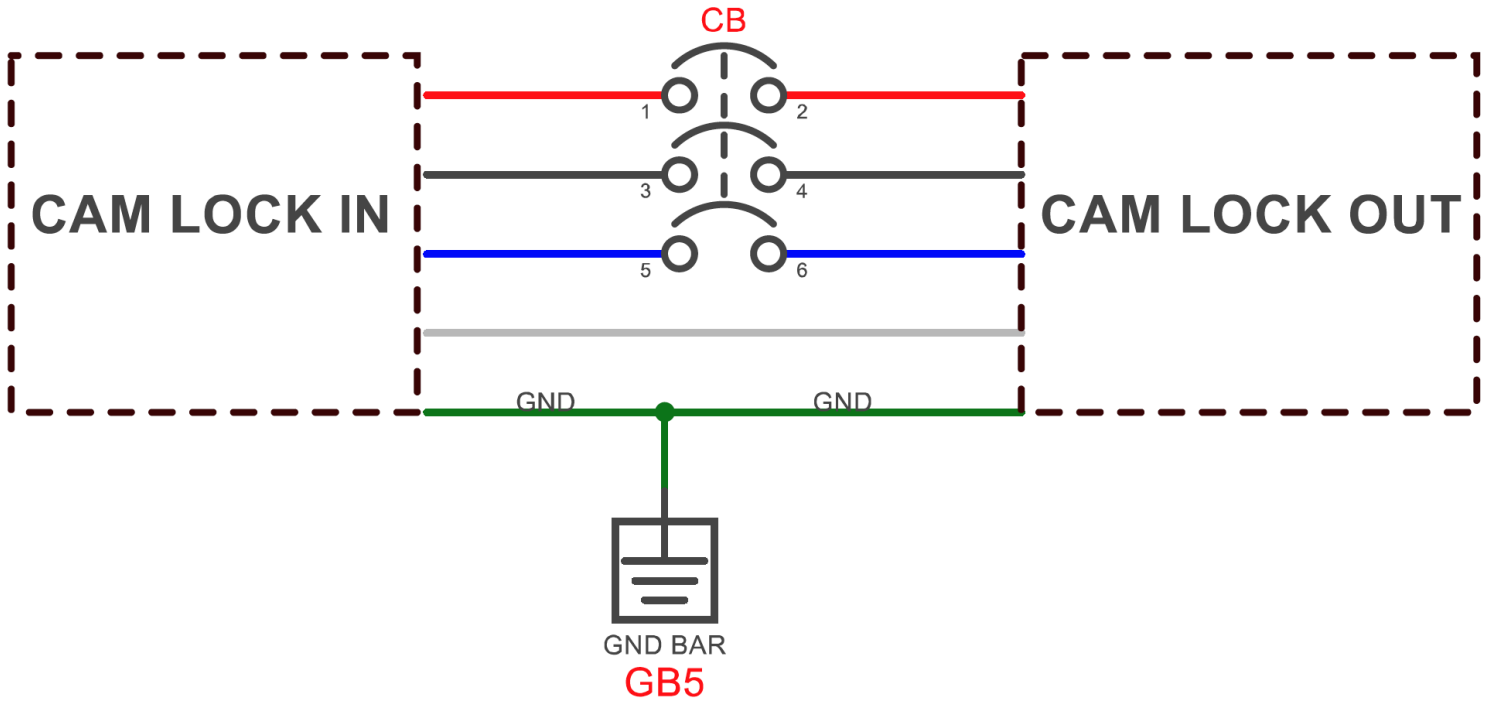

©2023 Eco Power Equipment Ltd. All rights reserved. All specifications are subject to change without notice.