

**Model**

**2001149**

**SBP-250-ALR, Three Phase**



## FEATURES

- |   |  |
|---|--|
| <ul style="list-style-type: none"> <li>• Prototype &amp; Production Tested Design</li> <li>• Wide range of options and accessories available</li> <li>• Simple access for maintenance and operations</li> <li>• Weatherproof enclosure with NEMA 3R compliance</li> <li>• Safety guards for all electrical connections</li> <li>• Lockable latches standard</li> <li>• All aluminum enclosure construction and design</li> <li>• Lockable latches standard</li> </ul> | <p><b>Panel Board</b></p> <ul style="list-style-type: none"> <li>• UL and CSA standards</li> <li>• Stackable design for unit storage</li> <li>• Heavy duty mobile rated design</li> <li>• Hard wire with aluminum gland or cam lock inlet</li> <li>• Bilingual decal package ready for all markets</li> <li>• All aluminum enclosure construction and design</li> <li>• Bilingual decal package ready for all markets</li> </ul> |
|---|--|

## UNIT SPECIFICATIONS

Rated Voltage	240 V AC 48 V DC
Rated Current	225 Amp
Branch Circuit Breaker Type	QOB QOB-VH QHB
Number of Phases	3
Rated Interrupt Current	10 kA 22 kA 65 kA
Connection Type	5 Wires (L1, L2, L3, N, GND)
Gland Type	Eco Power Equipment Standard Gland
Main Breaker SCCR Rating	100 kA @ 240 VAC
Length [INCHES]	38.6 in
Width [INCHES]	38.6 in
Height [INCHES]	27.75
Weight [LBS]	~98 lbs pending configuration
Compliance / Approvals	SPE-1000, UL67, CSAC22.2, UL1640 Compliant Design, UL 489, CE Compliant

# DIMENSIONS

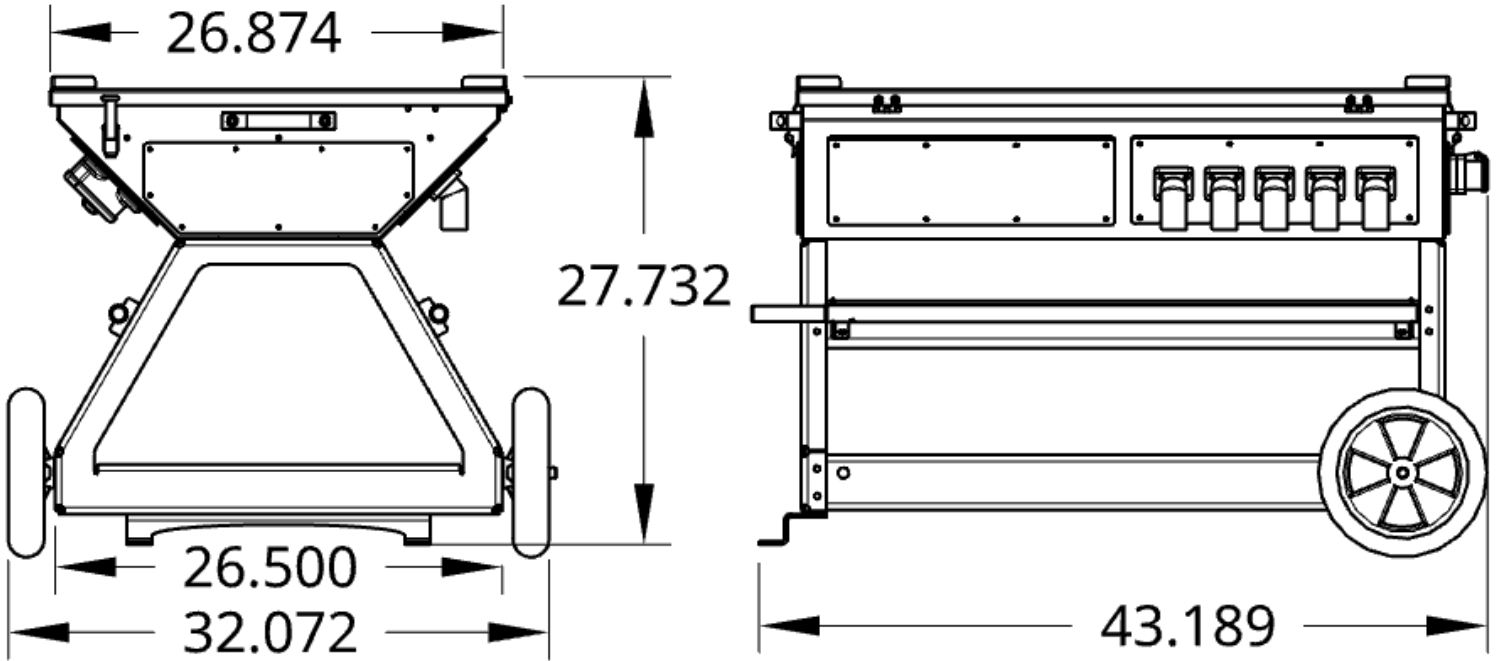

# BASE WIRING DIAGRAM

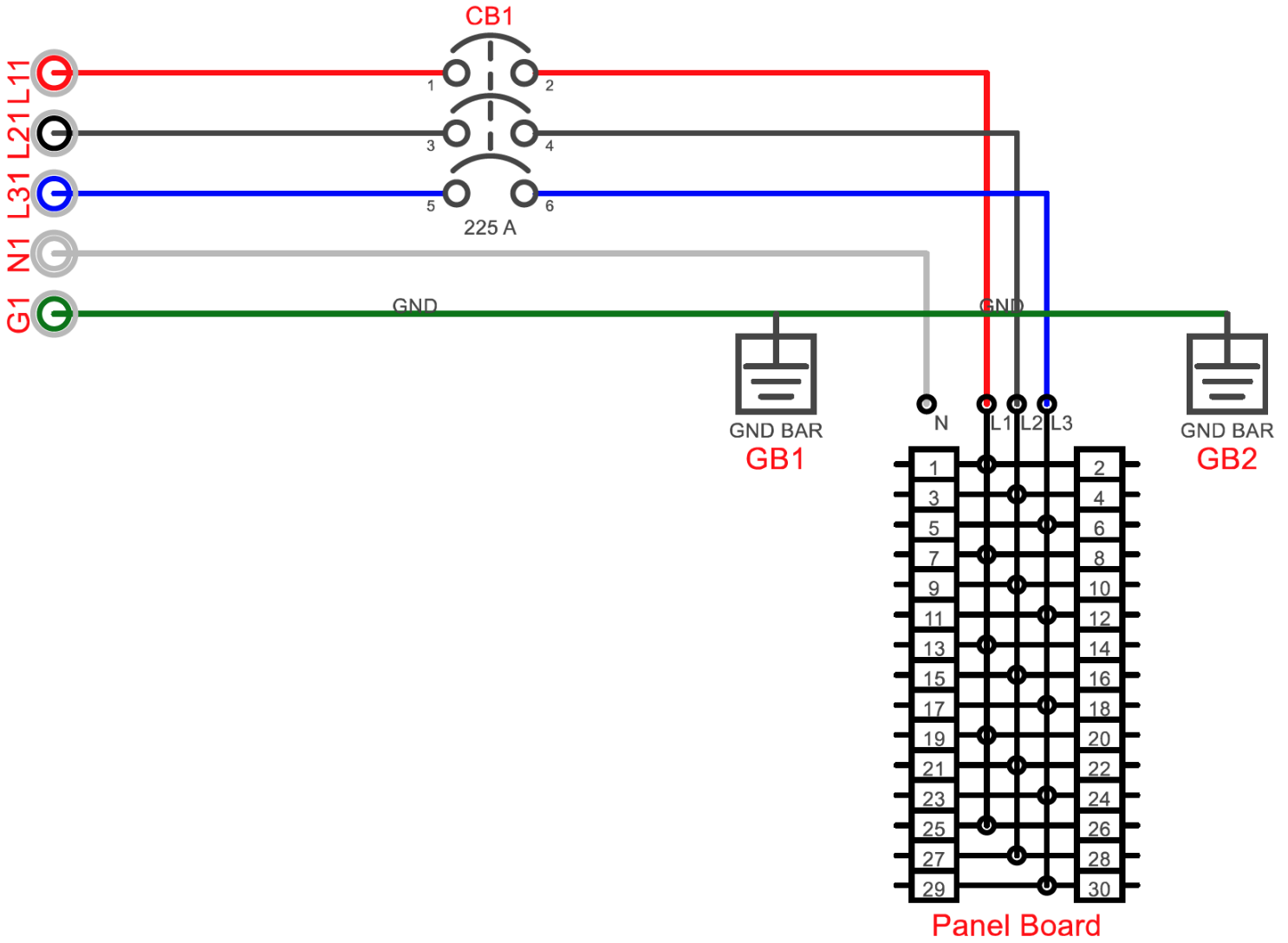

©2023 Eco Power Equipment Ltd. All rights reserved. All specifications are subject to change without notice