

Model

2001204

**SBP-800-ILINE Mobile I-Line
Distribution Panel**



FEATURES

- Prototype & Production Tested Design

- Wide range of options and accessories available

- Simple access for maintenance and operations

- Weatherproof enclosure with NEMA 3R compliance

- Safety guards for all electrical connections

- Lockable latches standard

I-LINE

- Circuit breaker power distribution I-LINES are for use on AC or DC systems.

- Hinged access door to make reconfiguration simple

- Heavy duty mobile rated design

- Aluminum glands for inlet and outlet

- Bilingual decal package ready for all markets

UNIT SPECIFICATIONS

Rated Voltage(s)

- 120/240Vac; 1-phase, 3-wire
- 240Vac; 1-phase, 2-wire
- 240Vac; 3-phase, 3-wire
- 240Vac Ground, B-phase; 3-phase, 3-wire
- 208Y/120Vac; 3-phase, 4-wire
- 480Y/277Vac; 3-phase, 4-wire
- 480Vac; 3-phase, 3-wire
- 600Y/347Vac; 3-phase, 4-wire
- 600Vac; 3-phase, 3-wire
- 125/250Vdc; 3-wire
- 250Vdc; 2-wire

Rated Current

800 Amps

Circuit Breaker Space

27 inches of circuit breaker space

Enclosure Rating

Name 3R

Branch Circuit Breaker Type

FA, FH, BD, BG, BJ, BK, HD, HG, HJ, HL, HR, QB, QD, QG, QJ, JD, JG, JJ, JL, JR, LA, LD, LG, LJ, LH, LL, LR, MG, MJ, PG, PJ, PK, PL, RG, RJ, RK, and RL.

Number of Phases

3

Rated Interrupt Current

Up to 200kA maximum (100kA@600Vac) when supplied by an I-Limiter™ circuit breaker.

Connection Type

5 Wire (L1, L2, L3, N, GND)
2 Per Phase and Neutral
1 Ground

Length [INCHES]

46 in

Width [INCHES]

28.75 in

Height [INCHES]

52.5 in

Weight [LBS]

TBD lbs

Compliance / Approvals

SPE-1000, UL67, CSAC22.2, UL1640 Compliant Design, UL 489, CE Compliant

DIMENSIONS

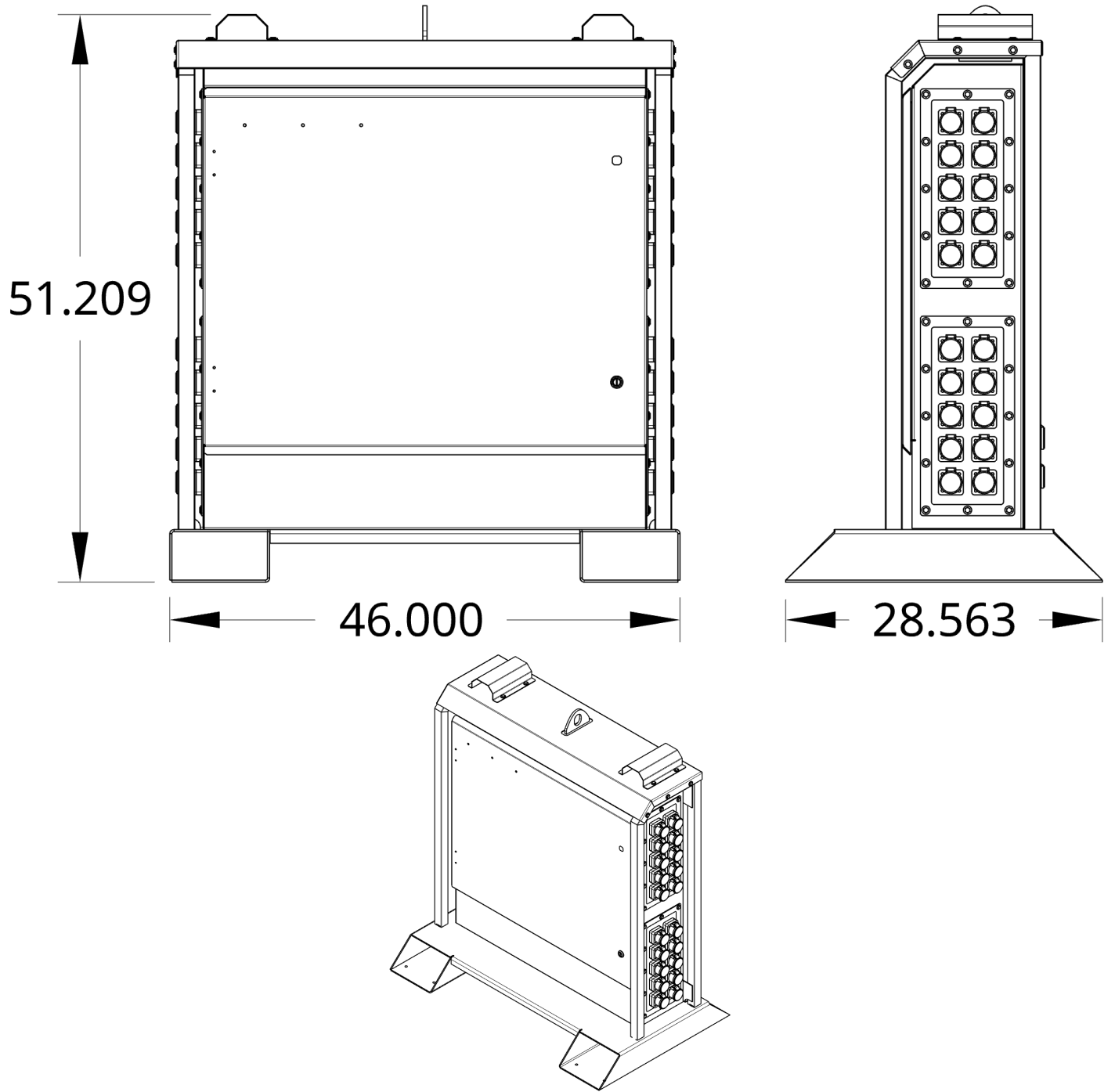

BASE WIRING DIAGRAM

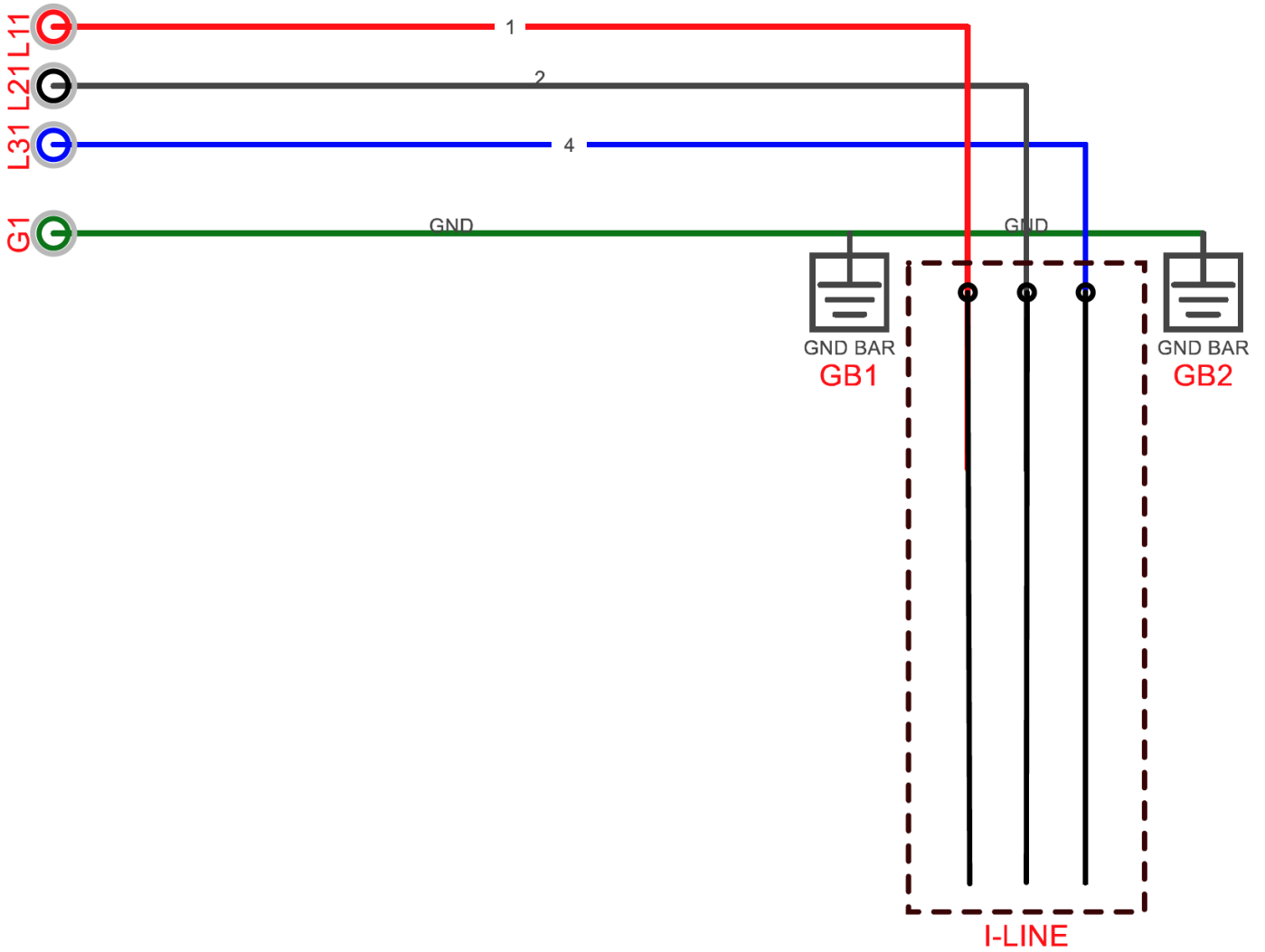

©2023 Eco Power Equipment Ltd. All rights reserved. All specifications are subject to change without notice.