

Operation and Maintenance Manual

Gas Engine

Model: WP04

WEICHAI AMERICA CORP.



Purpose

This manual is intended to inform customers on how to operate, install and maintain the Weichai America WP04 series gas engines. This document will be provided to customer so they can incorporate this information into their manuals and service documents.

Maintenance Providers

Maintenance and repair services may be performed by you or any qualified engine service provider that you choose. However, your engine warranty does not cover damage or failure caused by improper maintenance or repairs.

Owner's Manual & Maintenance Log Storage & Use

Store this Owner's Manual and Maintenance Log in a safe, visible place by your engine. The maintenance log must be updated whenever your engine is serviced.

Note

This manual may be updated from time to time by Weichai America Corp.

Operation and maintenance manual revision: September 2018

Table of Contents

Description of the Illustration Marks	5
Engine Introduction and Performance Parameters	6
1. Introduction of Engine Model	6
2. Engine Main Performance Parameters	6
3. WP04 Gas Engine Data	7
U.S. EPA Legal Requirements	8
Emission Related Installation Instructions	8
Personal Safety	9
Fuel Information	10
Oil and Coolant Information	10
New Engine Break-in Procedures	11
Engine Loading	11
Rating Definition for Power Generation	12
Engine Hoist	13
Extreme Operating Conditions	13
1. Engine Speed	13
2. Over Temperature	13
Engine Operation	14
1. Pre-Start Engine Check	14
2. Engine Starting	14
3. Performance	14
4. Engine Shut-Down	14
Service Intervals	15
Maintenance Intervals – Emergency	16
Maintenance Intervals– Non-emergency	17
WP04 Gas Engine Maintenance Procedures	18
1. Check Engine Oil	18
2. Check Coolant Level	18
3. Check Oil Pressure	19
4. Check Overall Operating Condition	19
5. Change Oil and Oil Filter	19
6. Engine Valve Lash Inspection/Adjustment	21
8. Check Air Filter	23

9. Replace Engine Breather Filter.....24

10. Inspect Belts, Pipes, Clamps and Hoses24

11. Inspect Ignition System.....24

12. Check Coolant Conditioner24

13. Inspect Water Pump24

14. Test and/or Replace Batteries24

Maintenance for Long-Term Storage.....25















Engine Fastener Torque Specifications.....26

Engine Service Schedule Log29

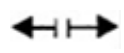
Engine Identification.....30

 PM INSPECTION Performed by:31

Description of the Illustration Marks

	Dismounting (assembly parts)		Oil Coating
	Fitting (assembly parts)		Special Tools
	Marking (do before disassembling, adjust when assemble)		Pay attention to assembly direction
	Filling – full charge (such as lubricating oil, cooling water, etc.)		Deflating
	Draining off (lubricating oil or cooling water)		Unloosing (such as: unloose clamping equipment)
	(Loose-proof-fixed) – Coat fluid sealant		Clamping (such as: reinforcing clamp equipment)
	Accident preventing (marks for dangerous occasion)		Inspecting – adjusting (such as: tightening torque, dimension pressure and clearance)
	Replacement during re-assembly		Inspecting

Engine Introduction and Performance Parameters

1. Introduction of Engine Model

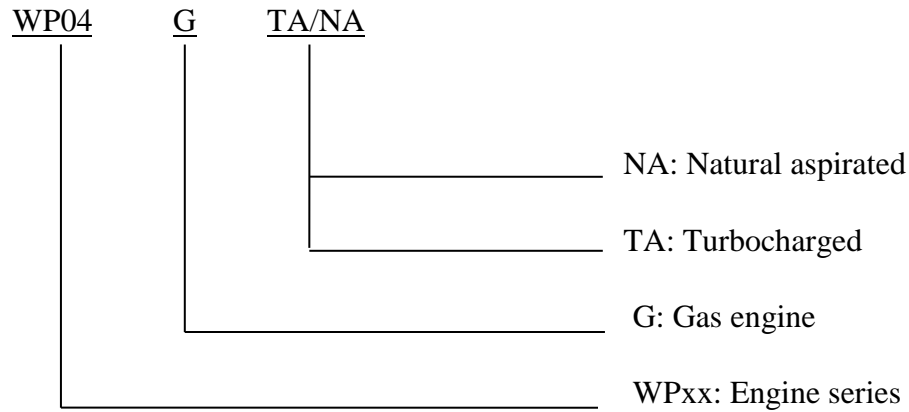

2. Engine Main Performance Parameters

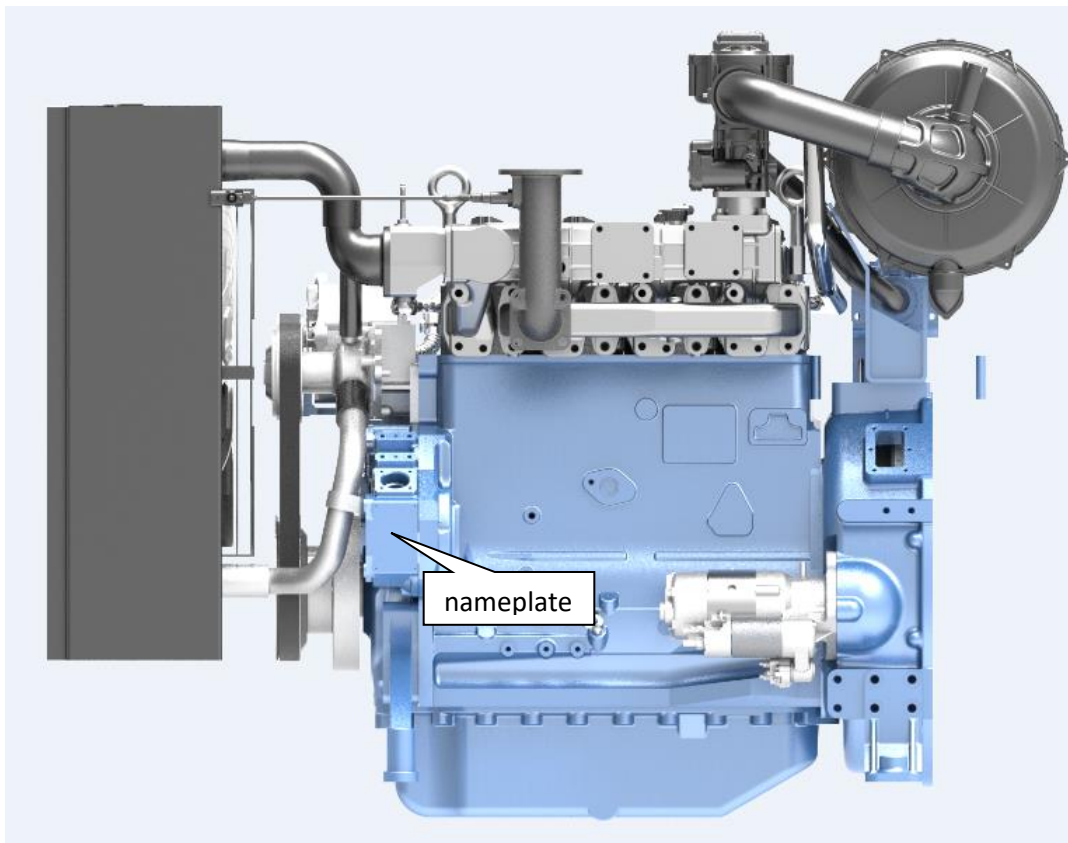

Illustration 1- Engine nameplate

See engine nameplate to find engine model, series number, rated power, rated speed and weight.

More data as following table:

3. WP04 Gas Engine Data

Item		Unit	Content
Engine type			WP04 naturally aspirated
Number of cylinders			4
Displacement		L	4.5
Cylinder bore * stroke		mm	105 * 130
Compression ratio			9.75:1
Idle speed		rpm	900
Fire order			1-3-4-2
Rotation			CCW viewed on flywheel
Oil pressure	Idle speed	KPA	≥120
	Rated speed	KPA	300~550
Oil temperature range (under rated condition)		°C	85~105
Oil capacity		L	9~12
Engine coolant capacity		L	Engine: 8L; engine and radiator: 19L
Intake valve lash (cold)		mm	0.2
Exhaust valve lash (cold)		mm	0.3
Spark plug gap		mm	0.3~0.35
Allow to tilt	Front / back	°	5/ 5
	Right / left	°	5/ 5
Weight		kg	560
Size (with radiator and air filter) (L*W*H)		mm	1433*774*1097

Note: Oil Viscosity should be determined based on Ambient Temperature Operations.

U.S. EPA Legal Requirements

This engine has been certified by the U.S. Environmental Protection Agency (EPA) as a Non-road and stationary constant-speed engine. It is illegal to operate this engine in a variable-speed (foot pedal speed control) application.

A maintenance plan and log provided within this manual are for you to record your engine maintenance. Update the log each time you service your engine.

NOTE

The repair shop or person of the owner's choosing may maintain, replace, or repair emissions control devices and systems. The emissions warranty is not conditioned on the engine being serviced by a Weichai America dealer or service establishment.

Emission Related Installation Instructions

WARNING

Failure to follow these instructions or installing a certified engine in a Non-Road equipment, violates Federal Law (40 CFR 1068.105(b)), subject to fines or other penalties as described in the Clean Air Act.

NOTE

To perform emission sampling, add a 20-centimeter extension to the exhaust pipe.

WARNING

This engine is only for constant-speed operation. Do not install the engine in variable-speed applications.

NOTE

If you install the engine in a way that makes the engine's emission control information label hard to read during normal engine maintenance, you must place a duplicate label on the equipment as described in 40 CFR 1068.105.

Personal Safety

WARNING

Improper operation of this machine could result in death or serious injury. Before operating any equipment, ensure every operator:

- Is instructed on safe operation and use of all equipment
- Fully understands all manuals and safety measures for all equipment before use
- Practices safety precautions for all equipment during operation
- Reads and fully understands all decals on equipment
- Clear the immediate area of all non-essential personnel before operating

WARNING

CALIFORNIA PROPOSITION 65

Engine exhaust from this production contains chemicals known to the State of California to cause cancer, birth defects and other reproductive harm.

CAUTION

Failure to follow these instructions could cause damage or decrease the life of equipment.

Weichai America Corp. is continually striving to improve its products and therefore reserves the right to make improvements and changes when it becomes practical and/ or possible to do so, without incurring any obligation to make changes or additions to previously sold equipment.

NOTE

All data given in this manual is subject to production variations. Operating and service messages displayed on the electronic operating panel may vary from what is shown in the Operator's Manual. Please adhere to the instructions displayed on the Electronic Operation Panel.

Fuel Information

Natural Gas

Your engine is certified to run on "pipeline-quality natural gas". Pipeline quality natural gas is supplied by a natural gas utility through a pipeline. It must be composed of at least 70% methane by volume or have a heating value of 950-1100 BTU per standard cubic foot (HHV). Maximum allowable H₂S is 55ppm.

Liquid Propane Gas (LPG)

HD5 grade propane which consists of minimum of 90% propane, maximum of 5% propylene, and maximum 5% of other gases (is o-butane, butane, methane, etc.) Maximum allowable H₂S is 55ppm.

Wellhead Gas (Non-Emergency Only)

Your WP04 naturally aspirated engine is certified to run on "wellhead-quality natural gas". It must have a heating value of 700-2362 BTU (a fuel switch should be used if above 1800BTU) per standard cubic foot (LHV). Maximum allowable H₂S is 55ppm.

Oil and Coolant Information

Natural Gas Engine Oil

Weichai America Corp. recommends using a straight weight or multi-weight low ash content oil specifically formulated for Natural Gas Engines. Specific weight depends on operating temperatures. Consult your oil supplier for specific product recommendations.

Relation between oil viscosity and ambient temperature			
	SAE Viscosity grade	Ambient temperature (°F)	Ambient temperature (°C)
Lubricant	0W-20	-31 to 68	-35 to 20
	5W-30	-22 to 86	-30 to 30
	10W-30	-12 to 86	-25 to 30
	15W-40	-4 to 104	-20 to 40
	20W-50	5 to 113	-15 to 45

API No. CI-4 or above are also recommended.

Engine Coolants

Weichai America Corp. recommends using a 50/50 mixture of fully formulated Ethylene Glycol or fully formulated Propylene Glycol coolant and distilled water. Follow recommended coolant maintenance practices by coolant supplier.

New Engine Break-in Procedures

The way any heavy-duty industrial natural gas engine is operated during the first 4 hours of service, will have a major impact on how well that engine will perform, how much oil it will consume and how long it will last. The engines moving parts are closely fitted for long service, and even though all Weichai America WP04 Gas Engines are run before they leave the factory, an additional period may be required before uniform oil films are established between all mating parts. The main purpose of break-in is to seat the compression rings to the cylinder walls.

It is recommended that during the first 4 hours of service:

1. Operate at one-half to three quarters load. Do not operate at maximum rated load for more than five (5) minutes at a time.
2. Do not run the engine unloaded for long periods as this will cause cylinder walls to “Glaze” before the piston rings seat properly and result in excessive lubricating oil consumption.

Engine Loading

The gas engines are designed to operate continuously at industry accepted high ratings and to provide optimum service life. It is not recommended to operate a natural gas engine continuously at low load levels. A general rule used for most low emission natural gas engines is to operate at 60% load or above.

Rating Definition for Power Generation

1. Continuous Power (COP) is defined as being the maximum power which the generating set is capable of delivering continuously whilst supplying a constant electrical load when operated for an unlimited number of hours per year. No overload capability is available for this rating.

2. Prime Power (PRP) is defined as being the maximum power which the generating set is capable of delivering continuously whilst supplying a variable electrical load when operated for an unlimited number of hours per year. The permissible average power output over 250 hours of operation shall not exceed 70%, the total time at full load over a year of operation shall not exceed 500h. It is allowed to overload 10% for 1 hour during 12 hours of operation but total time at overload shall be less than 25 hours per year.

3. Emergency Standby Power (ESP) is defined as the maximum power available during a variable electrical power sequence, under the stated operating conditions, for which a generating set is capable of delivering in the event of a utility power outage or under test conditions for up to 200 hours of operation per year. The permissible average power output over 24 hours of operation shall not exceed 80% of the ESP. The permissible time at full load shall be less than 25 hours per year.

See operating conditions as following table:

	Continuous Power (COP)	Prime Power (PRP)	Standby Power (ESP)
Annual working time	Unlimited	Unlimited	≤200 hours
Mean engine load factor	100%	≤70% per 250 hours	≤80% per 24 hours
Time at full load	Unlimited	≤500 hours per year	≤25 hours per year
Overload capacity	No	1 h per 12 hours (10% overload) ≤25hours per year	No

Engine Hoist

While lifting, the centerline of the crankshaft of the engine must be kept level; no tilt or single-point lifting. Lift and lower slowly (See Illustration 1)

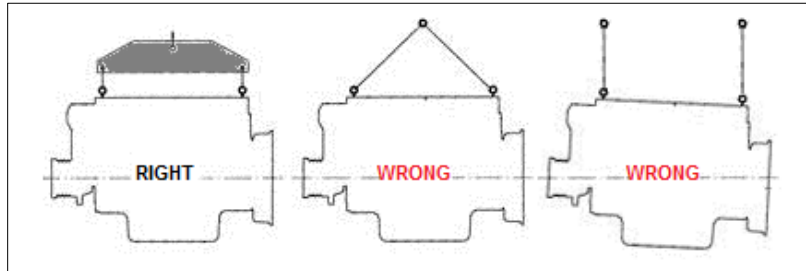

Illustration 2- Engine Installation Diagram

Extreme Operating Conditions

1. Engine Speed

This engine is designed to operate at constant speed (1000 to 2200 RPM) and should not exceed 2400 RPM for any length of time. If engine is operated at excessive RPM, fuel and ignition systems will shut down until engine RPM decreases to the recommended operating RPMs.

2. Over Temperature

CAUTION

To prevent engine damage, shut down engine immediately if the coolant reaches operating temperature above 230°F (110°C).

Normal operating temperature for this engine is 180°F to 200°F (82°C to 93°C)

Engine Operation

WARNING

The use of starting fluids could create an extremely hazardous condition and is not authorized with this engine. The use of starting fluid could cause severe injury and/or damage to equipment.

1. Pre-Start Engine Check

- Verify engine oil level is correct
- Verify engine coolant level is correct
- Inspect engine for leaks or a frayed belt or any condition or appearance out of the ordinary
- Verify all belts and moving parts are clear of obstructions
- Verify the “Check Engine” light is on with the key in the “ON” position and the engine not running (if applicable)

2. Engine Starting

With the controls in the idle position, start engine. To prevent damage to the starter, do not engage the starter motor for more than fifteen (15) seconds. Wait two (2) minutes between each start attempt to allow the starter motor to cool.

If oil pressure reading does not indicate normal oil pressure($\geq 120\text{kPa}$) within fifteen seconds of engine start, immediately shut down the engine to avoid damage to the engine. Service the engine prior to attempting to start engine again.

3. Performance

For monthly engine system check, idle the engine for at least one (1) minute before applying operating load. Verify the “Warning” light is not illuminated during engine operation. Inspect for fuel, coolant, and oil leaks with engine operating. If leaks are found, shut down engine and repair leaks before operating engine.

4. Engine Shut-Down

If engine has been running under load and reached operating temperature, run engine for five (5) minutes at idle without a load to allow engine to cool before engine shut down. The engine may run one to five seconds while the fuel is depleted from the engine’s fuel system.

Service Intervals

NOTE

Non-critical emission-related maintenance is not necessary to keep the emission-related warranty valid.

CAUTION

Failure to follow these scheduled maintenance intervals could cause engine damage or decreased engine life.

NOTE

Valve lash adjustments will be accomplished every 500 hours (1000, 1500, etc.) engine operating time on non-emergency.

NOTE

The oil change interval is based on “normal” operating conditions. Continuous operation during excessive hot or cold climate, constant operation with high loads, frequent starts and stops, poor quality lubricants and fuel contaminants would require more frequent oil change intervals to prevent shortening engine life.

NOTE

Always dispose of all chemicals and filters in accordance with Federal, State and Local laws and regulations.

Maintenance Intervals – Emergency

Preventative Maintenance Schedule – Emergency						
Event Number	Maintenance Event	Weekly	Interval			Every Two Years
			The first 50 hours	6 months	250 hrs or 1 year	
1	Check Engine Oil Level	X	X			
2	Check Engine Coolant Level	X	X			
3	Check Oil Pressure	X	X			
4	Check Overall Operating Condition (hose/clamp/pipe/belt/harness/connector)	X	X			
5	Change Oil and Oil Filter * (Sample)#				X	
6	Valve Lash (Inspect/Adjust)				X	
7	Spark Plugs (Check/Adjust/Replace)				X	
8	Check Air Filter * (Inspect/Replace)				X	
9	Replace Breather Filter				X	
10	Belts**, Pipes, Clamps and Hoses (Inspect/Replace)		X	X		
11	Check Ignition System (Plug Wires/Coils)			X		
12	Check Coolant Condition * (Sample)				X	
13	Inspect Water Pump				X	
14	Test Batteries & Alternator				X	
15	Replace Coolant					X

Table 1

- * Service may be required more frequently in dirty or extreme conditions; recommend sampling fluids.
- # Actual oil life and change interval is determined through engine oil sampling and analysis.
- ** It is recommended to replace Belt every 3 months.

WARNING

Before servicing engine, ensure the engine has stopped and all high voltage disconnect switches are in the open (disconnected) position.

CAUTION

Failure to follow these procedures could cause engine damage or decreased engine life.

Maintenance Intervals– Non-emergency

Preventative Maintenance Schedule – Non-Emergency							
Event Number	Maintenance Event	Weekly	Interval (Hours)			Interval	
			The first 50hours	500	1500	6 months	
1	Check Engine Oil Level	X	X				
2	Check Engine Coolant Level	X	X				
3	Check Oil Pressure	X	X				
4	Check Overall Operating Condition (hose/clamp/pipe/belt/harness/connector)	X	X				
5	Change Oil and Oil Filter * (Sample)#			X			
6	Valve Lash (Inspect/Adjust)			X			
7	Spark Plugs (Check/Adjust/Replace)				X		
8	Check Air Filter (Inspect/Replace)			X			
9	Replace Breather Filter				X		
10	Belts**, Pipes, Clamps and Hoses (Inspect/Replace)		X	X			
11	Check Ignition System (Plug Wires/Coils)			X			
12	Check Coolant Condition * (Sample)					X	
13	Inspect Water Pump					X	
14	Test Batteries & Alternator					X	
15	Replace Coolant	Every 2 Years					

Table 2

- * Service may be required more frequently in dirty or extreme conditions; recommend sampling fluids.
- # Actual oil life and change interval is determined through engine oil sampling and analysis.
- ** It is recommended to replace Belt every 3 months.

WARNING

Before servicing engine, ensure the engine has stopped and all high voltage disconnect switches are in the open (disconnected) position.

CAUTION

Failure to follow these procedures could cause engine damage or decreased engine life.

WP04 Gas Engine Maintenance Procedures

1. Check Engine Oil

- A. Ensure engine is level.
- B. Pull dipstick after the engine stop running at least 5 minutes.
- C. Ensure oil level is between high and low marks.

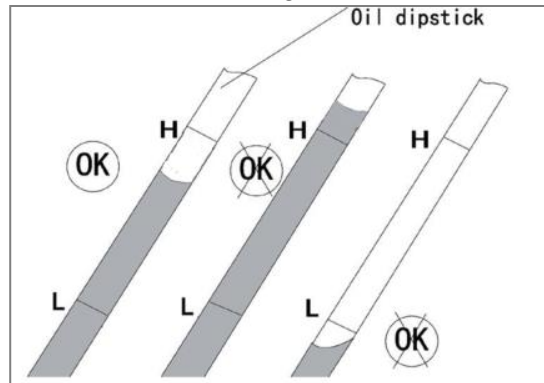

Illustration 3

- D. If the oil level is below the low mark, add additional oil as necessary.
- E. Install dipstick.

2. Check Coolant Level

Caution: Never remove radiator or top tank cap when coolant is hot! Burns and physical harm may occur.

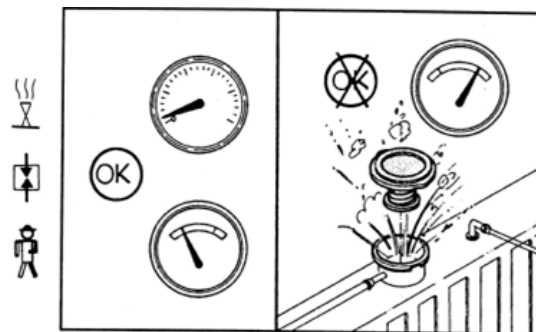

Illustration 4

- A. When coolant is room temperature or below, remove pressurized cap and inspect top tank or radiator for fluid level.
- B. If engine has a sight gauge or plastic top tank, a visual level check is adequate.
- C. If coolant level is low, determine reason for low fluid and top off with specified coolant.
- D. Test pressurized cap (replace if necessary or reinstall).

3. Check Oil Pressure

- A. When engine is running and at normal operating temperature, check oil pressure gauge.
 - i. Some engines will have an analog gauge and others will have an electronic gauge from the ECU.
- B. Ensure oil pressure is in the range of the table below both at idle and rated speed and operating temperature.

Oil Pressure		
Idle	PSI	KPa
Min	17	120
Rated Speed		
Min	43	300
Max	80	550

Table 3

4. Check Overall Operating Condition

- A. Inspect hoses, pipes and clamps for loose connections or leaks.
- B. Check the belt for fraying or damage.
- C. Look for fluid leaks under and around the engine.
- D. Inspect ignition wires and system for routing and connections.
- E. Inspect the engine harness for corrosion, abrasions, cuts or shorts.
- F. Look around engine for any debris or loose materials that might become a hazard.
- G. Assure battery voltage is $\geq 12v$ each and terminal connections are clean and tight.

5. Change Oil and Oil Filter

Materials:

Materials	QYT
Oil	9~12L; see dipstick
Oil filter	1

Table 4

NOTE: Recommended oil is: Natural Gas Engines Oil (NGEO); CI-4 or above.

NOTE: For continuous operation in extreme temperatures or in excessively dusty, dirty environments, rely on oil analysis to determine maintenance intervals.

NOTE: For best results, change engine oil while engine is still warm from operation.

- A. Remove the oil pan drain plug and drain oil completely.

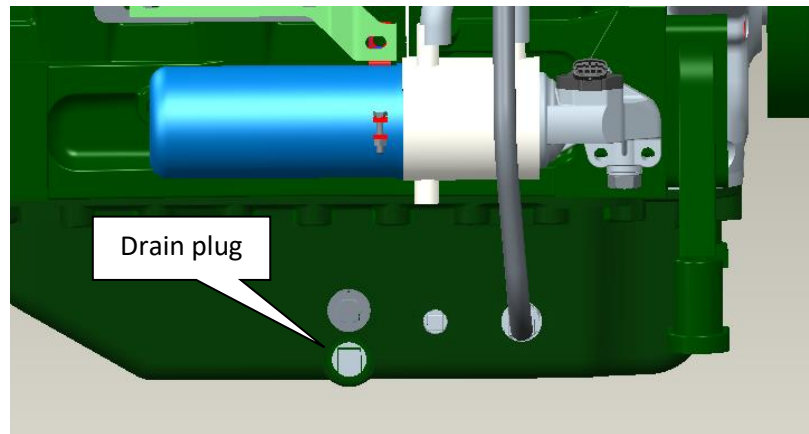

- B. Inspect drain plug washer (replace if necessary) and clean plug seating surface.
- C. Inspect magnetic plug for iron and ferrous material. If this exists, consider an oil analysis to determine source of debris.
- D. Reinstall drain plug and tighten securely.
- E. Remove the old filters by the filter wrench. Wipe filter base clean. Then apply a thin coat of motor oil to o- ring on new oil filter(s).
- F. Install oil filter. Tighten filter until the rubber gasket contacts base. Tighten additional 3/4 to 1 turn to seal.
- G. Using the recommended grade of oil, fill crankcase with specified quantity.

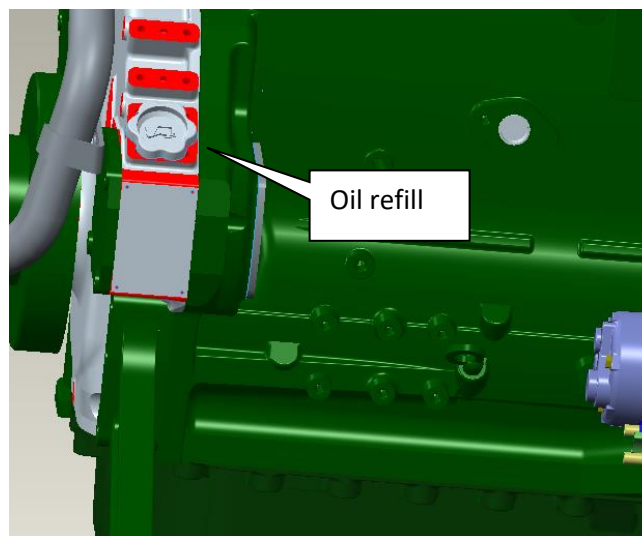

- H. Fill the grease cup of the signal generator with lithium grease (NLGI Gr. 2).
- I. Operate engine for five (5) minutes. Check for leaks at filter base and oil pan drain plug during operation.
- J. Shut down engine and wait five (5) minutes. Check engine oil level and adjust to proper level if necessary.

6. Engine Valve Lash Inspection/Adjustment

NOTE: Required every 500 hours (1000, 1500, etc.) on non-emergency.

NOTE

Confirm that #1 piston is on the compression stroke by turning both pushrods by hand to verify that both valves are closed. The valves are closed when the push rods are loose and can be turned easily.

Engine can be barred over by installing 8mm-1.25 bolts in the six empty holes around the crankshaft pulley and using a pry bar to turn the crankshaft.

- A. Remove all valve covers.
- B. Rotate the crankshaft until the number 1 piston is on the compression stroke and the timing pointer on the front cover is in-line with the "TDC" mark on the crankshaft damper. Some engines may have a permanent groove mark on the flywheel for "TDC".

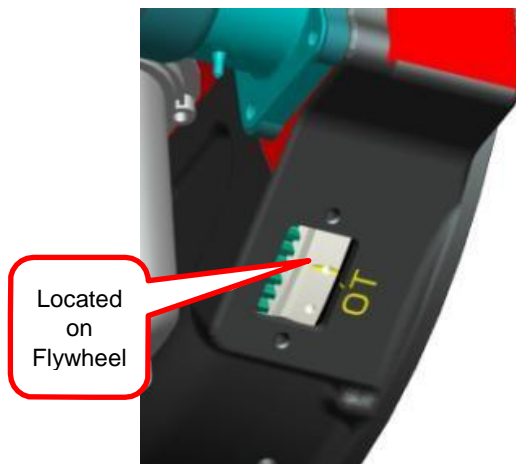

Illustration 5

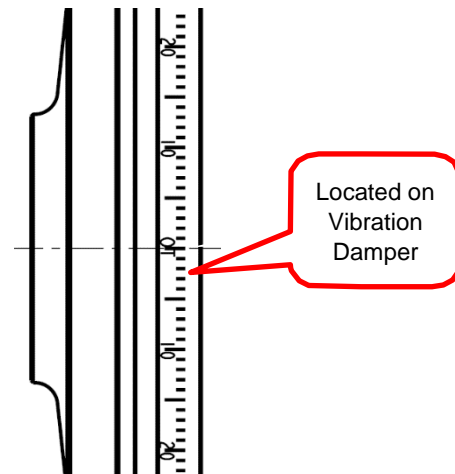

Illustration 6

- C. Using Illustration 9, adjust the four (4) valves corresponding with cylinder 1 "TDC". Insert the correct feeler gauge between the rocker arm and valve stem tip. Loosen the locknut and turn the valve adjustment screw until the rocker arm and valve stem tip contact the feeler gauge.
- D. Tighten the locknut once the valve is adjusted properly. Remove the feeler gauge. A very slight resistance should be felt when removing the feeler gauge.

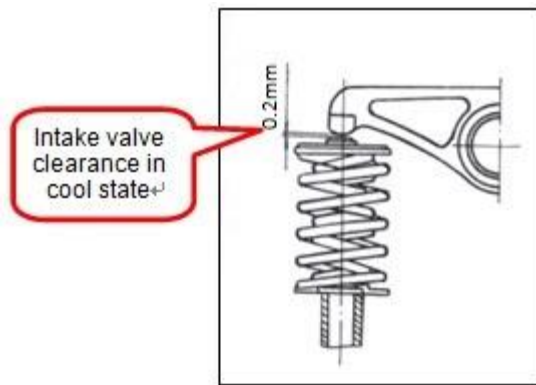

Illustration 7

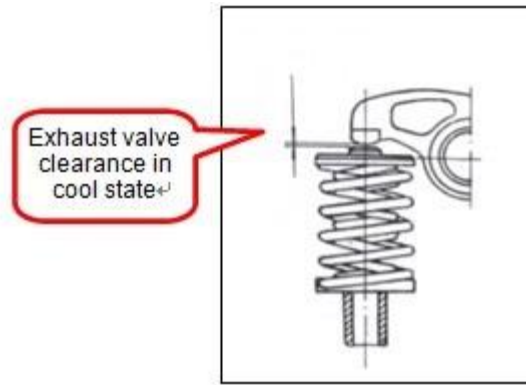

Illustration 8

- E. Rotate the crankshaft (360°) until the number 4 piston is on the compression stroke and the timing pointer on the front cover is in line with the “TDC” mark on the vibration dampener.
- F. Using Illustration 10, adjust the four (4) valves corresponding with the cylinder 4 “TDC”. Insert the correct feeler gauge between the rocker arm and valve stem tip. Loosen the locknut and turn the valve adjustment screw until the rocker arm and valve stem tip contact the feeler gauge.
- G. Tighten the locknut once the valve is adjusted properly. Remove the feeler gauge. A very slight resistance should be felt when removing the feeler gauge.

NOTE

Ensure valve cover is completely seated and not resting on bolts or washers adjacent to the valve cover.

- H. Install gasket onto the valve cover and align the cover and gasket onto the cylinder head. Tighten the valve cover mounting bolts to 36 in/lbs. Ensure valve cover gasket is aligned before tightening.

With #1 piston at “TDC”, adjust these valves to: **WP04GNA Exhaust 0.3mm/0.012” / Intake 0.2mm/0.008”**;

	INT	EXH	INT	EXT
#1@TDC	1	1	2	3

Illustration 9

With #4 piston at “TDC” adjust these valves to: **WP04GNA Exhaust 0.3mm/0.012” / Intake 0.2mm/0.008”**;

	EXH	INT	EXH	INT
#4@TDC	2	3	4	4

Illustration 10

7. Inspect Spark Plugs

- A. Inspect high tension leads from coils for shorts, cracking and damage. (if used)
- B. Remove/blow out any debris from the cylinder head spark plug hole before removing the spark plug to prevent any debris falling into the combustion chamber.
- C. Remove wires or coil on plug (COP) from spark plugs.
- D. Remove the spark plug and inspect the electrode and threads for wear or debris.
- E. If the plugs do not show wear or debris or damage, re-gap and reinstall (**WP04GNA: 0.014”/0.35mm gap**).
- F. If the plugs have debris or wear or damage, replace with new plug.

CAUTION

Before installing spark plug, ensure plug and cylinder threads are clean and undamaged. Torque spark plugs to specifications. Over-tightened can cause damage and removal of spark plug difficult. Under-tightened could cause the spark plug to overheat, resulting in pre-ignition and possible engine damage.

- A. Install new spark plug. Torque to 18 – 20 ft. lbs. (25 – 28N·m)
- B. Apply spark plug boot dielectric grease to inside of boot.
- C. Reconnect the spark plug wire or COP to the spark plug in the proper order.

8. Check Air Filter

- A. Inspect the air filter reminder.
- B. Record the reading on the gauge.
- C. If the reading is in the red, replace filter, and reset the gauge.
- D. If the reading has decreased significantly from the last reading, check for leaks, holes in the filter or leakage paths – replace/repair as necessary.
- E. If filter minder is the same as last reading or higher but not in the red, leave filter in place.
- F. After each air filter check, record and reset the gauge.

NOTE: Do not attempt to blow out, jar debris loose, or otherwise tap filter in an attempt to clean the filter.

9. Replace Engine Breather Filter

- A. Unscrew breather housing top counter-clockwise.
- B. Pull top of filter element up and remove filter.
- C. Install new filter element and breather housing top.

10. Inspect Belts, Pipes, Clamps and Hoses

- A. Inspect hoses, pipes, clamps, for loose connections, aging, corrosion or leaks.
- B. Check the belt for fraying or damage. Replace if necessary.
- C. Look for fluid leaks under and around the engine.

11. Inspect Ignition System

- A. Complete procedure #7 above, and also inspect coils for cracks, heat duress, and any damage.
- B. Ensure all connections are secure.
- C. Ensure the high tension leads are routed around any heat sources, circuit boards or sharp objects that might damage the leads or if COP assure tight mounting.

12. Check Coolant Conditioner

- A. When coolant is at room temperature or below, remove a sample of coolant and measure the levels of coolant additives with a test strip (applies to conventional coolants only).
- B. Replace coolant or additive package if necessary or every two years. Ensure 50/50 mixture
- C. Remove thermostat & replace with new as needed or every two years during coolant change & flush.
- D. Run engine until thermostat opens, and allow engine to cool to inspect coolant level.
- E. Reinstall radiator cap tightly.

13. Inspect Water Pump

- A. Check the water pump and gasket for leak.
- B. Inspect water pump weep holes for signs of leakage under pressure while pressure test cooling system.

14. Test and/or Replace Batteries

- A. Disconnect negative cables from batteries.
- B. Disconnect positive cables from batteries.
- C. Test each battery individually.
- D. Remove old batteries (if necessary) and install new one (s).
- E. Connect positive cables. Clean if required.
- F. Connect negative cables. Clean if required.
- G. Start engine and test alternator for proper operation.

Maintenance for Long-Term Storage

Weichai America Corp. runs all completed engines prior to shipping to customers. Your engine was hot tested and calibrated using fully formulated coolant in the cooling system and Mobil Pegasus 805 40W Natural Gas Engine Oil prior to being drained and shipped to you. Your engine can be stored Six (6) to twelve (12) months depending on humidity control in storage without any further service. Engines stored outdoors or in a high humidity environment may require more frequent treatment. All engine openings should be covered when you receive your engine. Please be sure to keep engine openings sealed during engine storage. In the event that your engine will be stored for extended times, you will need to follow recommended procedures for preserving your engine from rust.

No service to the cooling system should be required for engines stored less than one (1) year. If storing an engine for more than one year, remove thermostat(s), flush engine coolant passages with straight antifreeze solution, cover all openings, and return to storage.

Other procedures for storage:

- Fill or mix a preservative oil according to oil manufacturer's instructions. Mobilarma 524 or equivalent. Consult with your oil supplier for comparable products. Operate engine at high idle, no load until it reaches operating temperature in order to coat all surfaces with preservative oil solution.
- If engine is not runnable, crank for a maximum of 30 seconds with two minute rests between cranking until all surfaces are coated. If unable to crank engine, bar engine over several times and use a spray to put preserving oil solution into the cylinders through spark plug holes, intake and exhaust ports, turbo inlet, etc. This will require a different mixture in order to penetrate and coat internal surfaces. Mobil Vaprotec Light or equivalent product. Consult with your oil supplier for comparable products.
- Clean the engine of dirt, rust, oil, water, etc. Inspect exterior and paint any areas required. Contact your Weichai America parts supplier for touch up Weichai blue paint.
- Brush or spray all unpainted steel or iron surfaces such as flywheels, gear teeth, and starter pinions, with a preserving solution. Mobilarma 247 or equivalent. Consult with your oil supplier for comparable products.
- Remove tension from all belts.
- Cover and seal all openings. Tag with date and procedure used to preserve.
- Cover engine but allow for air circulation to prevent condensation.
- Inspect periodically and reapply preservative oil solution if necessary.
- Follow preservative oil manufacturer's instructions for startup when removing engine from storage.

Engine Fastener Torque Specifications

Fastener's Name	Bolt Specification	Tightening torque (N·m) + further turned angle (°)	Permissible times of repeat used
Main bearing*	M14-10.9	70N·m + (90±4°), required sequence of tightening (See illustration13)	2
Connecting rod*	M12x1.5-12.9	30N·m + (60±4°), (Reach 85 to 135N·m at the same time)	0
Cylinder head*	M14-12.9	30N·m +2x (120±4°), required sequence of tightening (See illustration14), (Reach 230 to 300N·m at the same time)	3
Flywheel housing*	10.9	M10-10.9: 80-85Nm; M12-10.9: 140-145Nm	
Flywheel*	M16-12.9	(290±5) N·m	2
Camshaft gear	M10/M8-12.9	M10: (85-90) N·m; M8: (55-60) N·m	2
Valve cover		(10-15) N·m	
Oil pan		(20-35) N·m	
Balance mechanism	4XM10	(35+5) N·m	
Intermediate gear		(65-70) N·m	
Exhaust manifold	M10	(65-80) N·m	
Intake manifold	M10	23 N·m	-
Crankshaft pulley	M16-12.9	(300-310) N·m	-
Damper	M10-10.9	(65-70) N·m	-
Rocker seat	M10-8.8	(40-45) N·m	-
Spark-plug	M14x1.25	(25-28) N·m	-
UEGO sensor	M18x1.5	(40±5) N·m	-
Water temperature sensor	M14x1.5	(25±5) N·m	-

- ① Values of superscript and subscript are permissible tolerance ranges
 ② The angle value is the further turned angle after reaching the specific torque
 ③ The number before the angle is the number of time to turn the angle
 ④ There are corresponding requirements on the strength classes of the bolts and nuts used at various positions of the engine. It is forbidden to interchange the bolts and nuts of the same size but of different strength classes. It is impermissible to exceed the allowed times of repeat use. Otherwise it will bring about severe outcome.
 *It is required to apply oil on bolt spread and contact surface

Table 5

CAUTION

Failure to follow these instructions could cause damage or decrease the life of equipment.

Note in above Table 5 that connecting rod bolts cannot be re-used.

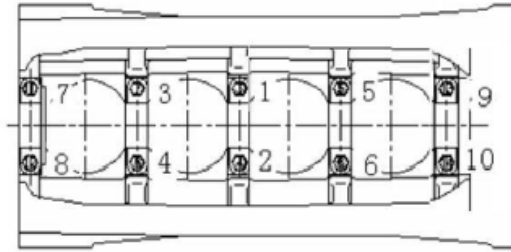

Illustration 13

Torque Head Bolts

NOTE: Cylinder head bolts are allowed to be reused and torqued only three (3) times. Discard these bolts after the third torque because they lose their elasticity and strength and should not be torqued for a fourth time. Remove cylinder head covers.

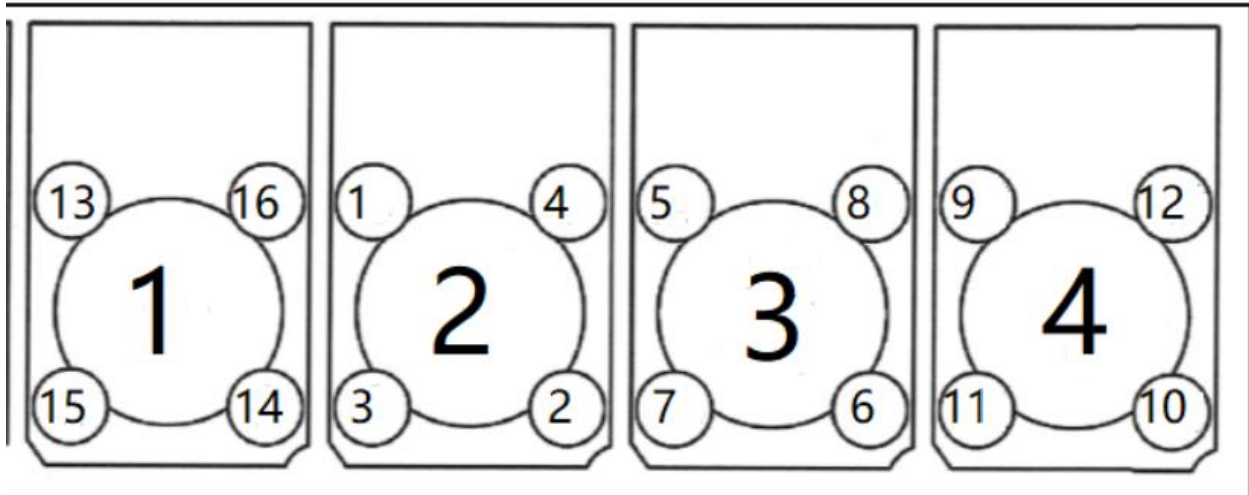

Illustration 14: Tighten order of cylinder head bolt

Tightening Process is as follows:

- a. After lubricating bolt and thread part, tighten the bolts to 30N·m; follow the order in Illustration 14.
- b. Turn the bolt to $120\pm 4^\circ$; follow the order in Illustration 14.
- c. Turn the bolt to $120\pm 4^\circ$ again, and meanwhile the torque reaches to 230 to 300N·m; follow the order in Illustration 14.

Strength Class	0.125 (Galvanized)				0.14 (Bright)			
	6.9	8.8	10.9	12.9	6.9	8.8	10.9	12.9
Bolt Specs	Recommended Torque (Nm)							
M4	2.3	2.7	3.8	4.6	2.4	2.9	4.1	4.9
M5	4.7	5.5	8.0	9.5	5.0	6.0	8.5	10
M6	8.0	9.5	13.0	16.0	8.5	10	14.0	17
M8	19	23	32	39	21	25	35	41
M10	39	46	64	77	41	49	69	83
M12	67	80	110	135	72	86	120	145
M14	105	125	180	215	115	135	190	230
M16	165	195	275	330	180	210	295	355
M18	225	270	390	455	245	290	405	485
M20	325	385	540	650	345	410	580	690
M22	435	510	720	870	465	550	780	930
M24	560	660	930	1100	600	710	1000	1200
M27	830	980	1400	1650	890	1050	1500	1800
M30	1100	1350	1850	2250	1200	1450	2000	2400
M8x1	21	25	35	42	23	27	38	45
M10x1.25	41	49	66	82	44	52	73	88
M12x1.25	74	88	125	150	80	95	135	155
M12x1.5	70	83	115	140	76	90	125	150
M14x1.5	115	140	195	235	125	150	210	250
M16x1.5	175	210	295	350	190	225	315	380
M18x1.5	255	305	425	510	275	325	460	550
M20x1.5	360	425	600	720	385	460	640	770
M22x1.5	480	570	800	960	520	610	860	1050
M24x1.5	610	720	1000	1200	650	780	1100	1300
M27x1.5	890	1050	1500	1800	970	1150	1600	1950
M30x1.5	1250	1450	2050	2500	1350	1600	2250	2700

Table 6

Engine Service Schedule Log

Service Interval (hr.)	Service Date	Start Time	Complete Time	Hour Meter	Comments	Initial
50						
500						
1000						
1500						
2000						
2500						
3000						
3500						
4000						
4500						
5000						
5500						
6000						
6500						
7000						
7500						
8000						
8500						
9000						

Engine Identification

Engine Part Number: _____

Engine Serial Number: _____

Engine Application: _____

Purchased From: _____

In-Service Date: _____

Engine Hours at Delivery: _____

PM INSPECTION Performed by: _____

UNIT # _____ DATE: _____ HOURS: _____

WORK ORDER# _____

PM TYPE: hr. mo/yr Codes: OK Needs Follow Up Adjustment Made

ENGINE COMPARTMENT INSPECTION

CHECK ENGINE OIL LEVEL	REPLACE BREATHER FILTER
CHECK ENGINE COOLANT LEVEL	INSPECT BELTS, PIPES, CLAMPS & HOSES
CHECK OIL PRESSURE	IGNITION SYSTEM (PLUG WIRES/COILS/COP)
CHECK OVERALL OPERATING CONDITION	CHECK COOLANT CONDITIONER (SAMPLE) REPLACE COOLANT AS REQUIRED
CHANGE OIL & OIL FILTER (SAMPLE)	INSPECT WATER PUMP
ADJUST VALVE LASH	TEST BATTERY & ALTERNATOR
SPARK PLUGS (CHECK/ADJUST/REPLACE)	INSPECT TURBOCHARGER
CHECK AIR FILTER (INSPECT/REPLACE)	

NOTES

1. _____

2. _____

3. _____

4. _____

5. _____

- 6. _____

- 7. _____

- 8. _____

- 9. _____

- 10. _____

- 11. _____

- 12. _____

- 13. _____

- 14. _____



Weichai America Corp.

3100 Golf Road
Rolling Meadows, IL 60008
<http://www.WeichaiAmerica.com/>